

# Compression Load Cell



## Features

- Capacity 1kg-200kg
- Both compression and tension
- Compact size
- Stainless steel

## Optional features

- Hermetically sealed available

## DESCRIPTION

The ZMWMC is constructed from stainless steel and protected from moisture with an epoxy bonded cover. ZMWMC is configured for both of compression and tension force measurement. Full-bridge, bonded foil strain gauge technology provides excellent long-term stability and ensures high performance even in applications requiring in excess of 1 million load cycles.

## DIMENSIONS (mm)

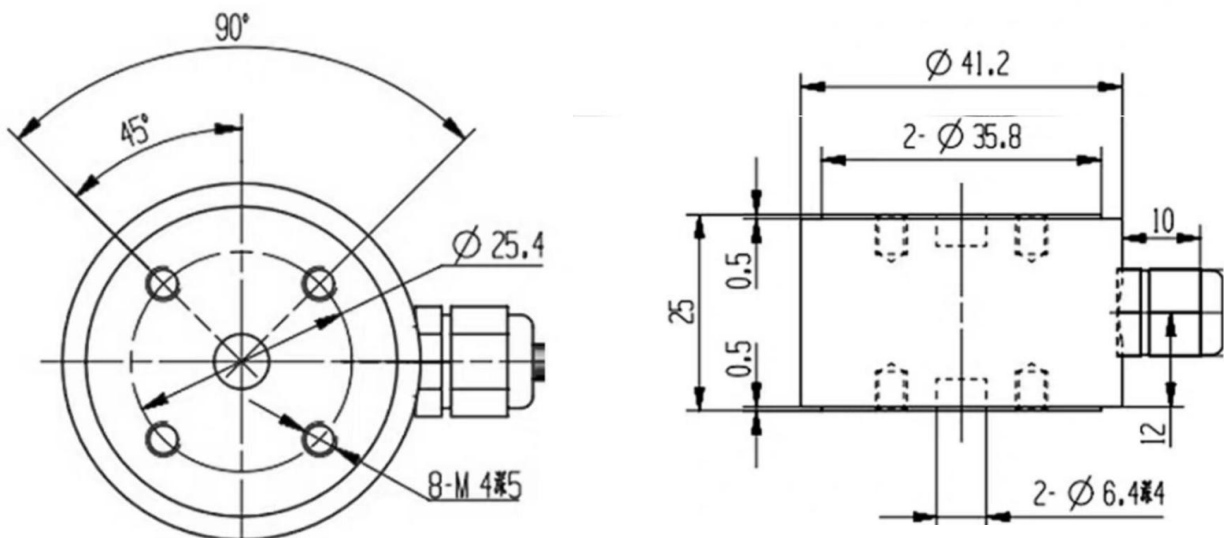

## SPECIFICATIONS

PARAMETER	VALUE	UNIT
Standard capacities (E <sub>max</sub> )	1-200	KG
Rated output-R.O.	2.0	mV/V
Zero balance	1	±% of rated output
Non linearity	0.1	±% of rated output
Hysteresis	0.05	±% of rated output
Non-repeatability	0.05	±% of rated output
Creep error (30 minutes)	0.05	±% of rated output
Zero return (30 minutes)	0.05	±% of rated output
Temperature effect on min. dead load output	0.0026	±% of rated output/°C
Temperature effect on sensitivity	0.0015	±% of rated output/°C
Compensated temperature range	-10 to +40	°C
Operating temperature range	-20 to +60	°C
Safe overload	150	% of R.C
Ultimate overload	200	% of R.C
Excitation, recommended	10	Vdc
Excitation, maximum	15	Vdc
Input resistance	380±10	Ohms
Output resistance	350±3	Ohms
Insulation resistance	5000	Mega-Ohms
Material	Stainless steel	
Protection class	IP66	

All specifications listed subject to change without notice.